

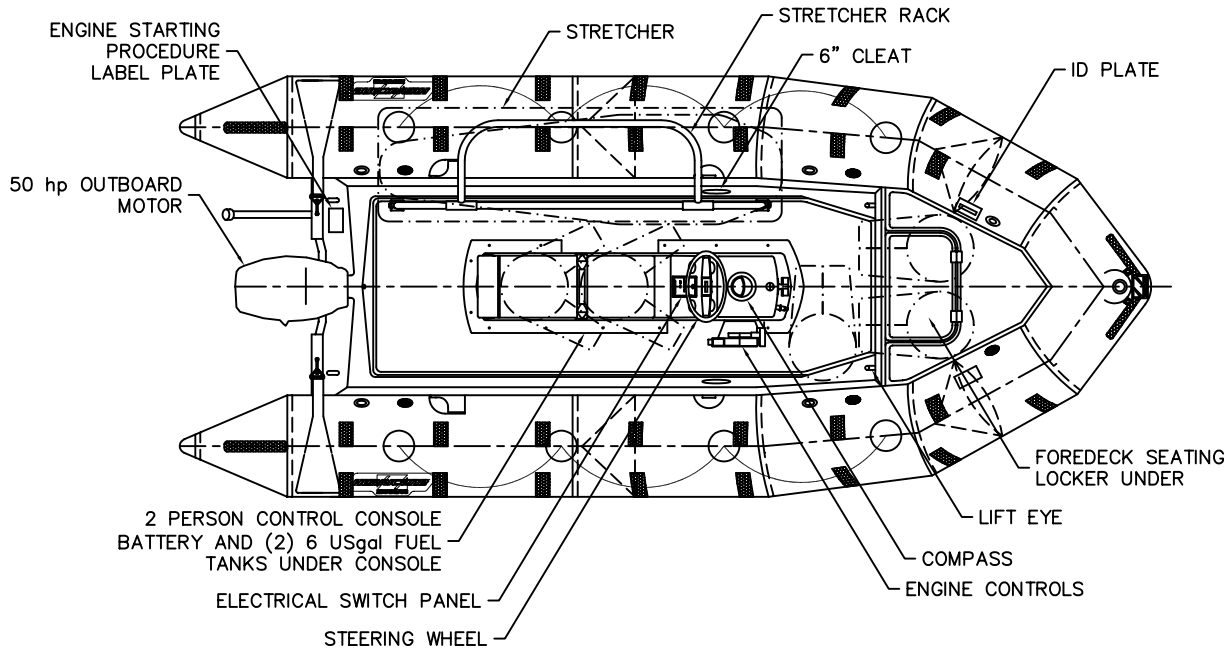

ZODIAC HURRICANE TECHNOLOGIES INC.

H472S SAR

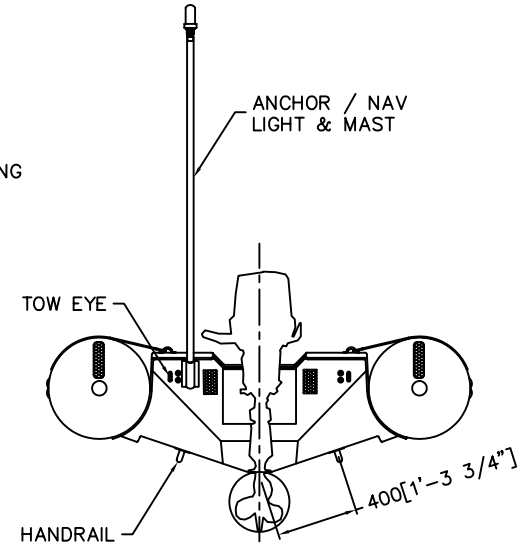
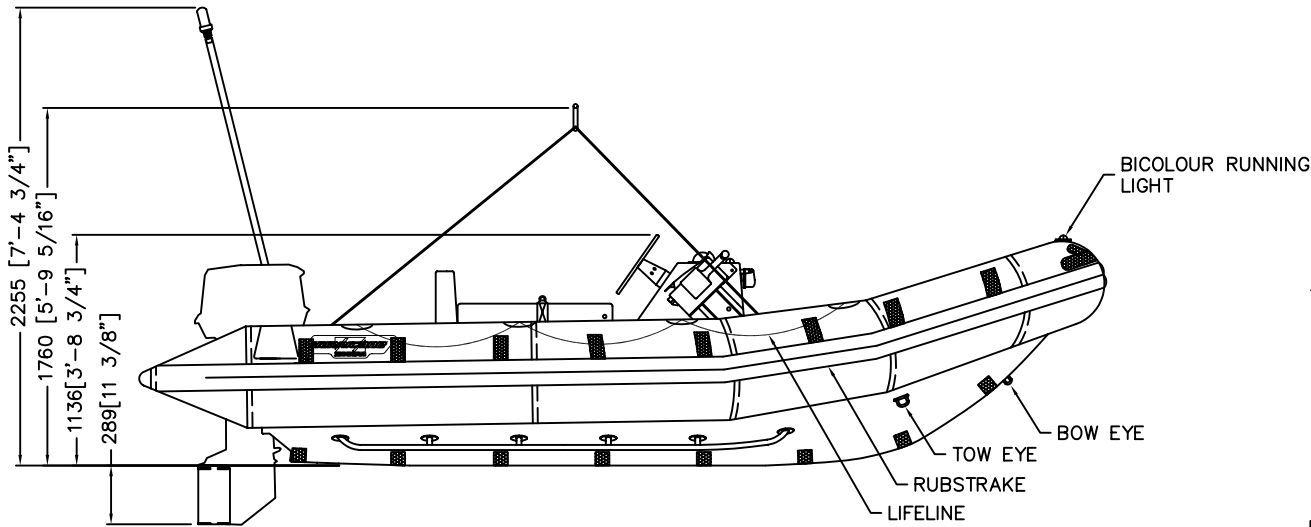

SPECIFICATIONS:

OVERALL LENGTH	-----	15'-5" (4.70 m)
OVERALL BEAM	-----	6'-7" (2.05 m)
WEIGHT (SOLAS CONDITION "A")	-----	864 lbs (392 kg)
WEIGHT (SOLAS CONDITION "B")	-----	2012 lbs (913 kg)
BUOYANCY TUBE DIA.	-----	1'-8" (0.50 m)
MAX HORSE POWER	-----	70 hp
CAPACITY	-----	6 PERSONS
FUEL	-----	TOTAL 12 USgal (45.50 l)

NOTE:

THE NAME AND PORT OF REGISTRY WILL BE PERMANENTLY MARKED ON THE BOW WITH INDELIBLE 75mm HIGH LETTERS. ALL INDELIBLE MARKINGS MADE ON THE HYPALON TUBESET WILL BE MADE WITH HYPALON PAINT. RETRO REFLECTIVE TAPE ON TUBESET IS FITTED IN ACCORDANCE WITH AN INFLATED RESCUE BOAT. RETRO REFLECTIVE TAPE ON HULL FITTED IN ACCORDANCE WITH RIGID RESCUE BOAT REQUIREMENTS.

THIS DRAWING SHALL REMAIN THE PROPERTY OF ZODIAC HURRICANE TECHNOLOGIES INC. AND IS SUBJECT TO RECALL AT ANY TIME. MATERIAL DESCRIBED HEREIN OR PARTS THEREOF MAY NOT BE REPRODUCED, USED, MANUFACTURED OR PUBLICIZED WITHOUT WRITTEN PERMISSION FROM ZODIAC HURRICANE TECHNOLOGIES INC.