



**ZODIAC SEA-RIDER 4.7**

P/N Z85501

Rev 1 – June 1<sup>st</sup> 10  
TECHNICAL DATA SHEET



***World's Toughest RIBs***

The SeaRider has been proven in operation use around the World, by both Military & Professional operators; with its unique water ballast system and deep “V” hull, giving the craft exceptional sea keeping capabilities, yet still offering high performance and manoeuvrability in the heaviest of seas.

The Zodiac SeaRider can be ship launched, and if required, self righting equipment, and inboard variants can be supplied on certain models.

Zodiac has been at the forefront of the design and development of RIBs since its onset. Zodiac a name you can trust.

**Important Note:** Boats available in North America may have different specifications.

THIS MATERIAL CONTAINS PROPRIETARY DATA BELONGING TO ZODIAC INTERNATIONAL. UNAUTHORIZED DISCLOSURE, USE OR REPRODUCTION WILL RESULT IN LIABILITY. ZODIAC RESERVES THE RIGHT TO CHANGE THE SPECIFICATIONS OF THIS TECHNICAL DATA SHEET WITHOUT NOTICE.

Dimensions and weight + or - 3 % (5% on prototype)

page 1 / 5



**SR 4.7 – BOAT DEFINITION**

**CAPACITY**

. maximum number of persons :	<b>8</b>	
. maximum load (persons, motor & gear) :	<b>815 kg</b>	1797 lb
. floorboard usable area :	3,27 m <sup>2</sup>	35.2 ft <sup>2</sup>
. buoyancy tube volume :	1,44 m <sup>3</sup>	50.8 ft <sup>3</sup>

**DIMENSIONS**

. overall length :	4.74 m	15' 6"
. inside length :	3.4 m	11' 2"
. overall width :	2.03 m	6' 7"
. inside width :	1.07 m	3' 5"
. weight empty :	250 kg	551 lb
. buoyancy tube diameter :	0,5 m	19.5"

**SAFETY / INFLATION**

. airtight compartments :	5
. inflation valve :	5

**ENGINE POWER**

. engine shaft length :	L (20")	
. useful HP range :	25-60 HP	
. maximum HP:	70 HP	
	2 x 30 HP	
. maximum weight of engine :	130 kg	287 lb
	2 x 65 kg	2 x 144 lb

**FABRIC**

- . main buoyancy tubes : **Military Grey, 1670 dtx**, polyester, Hypalon/neoprene
- . baffles : **Black, 940 dtx**, polyester, Hypalon/neoprene

THIS MATERIAL CONTAINS PROPRIETARY DATA BELONGING TO ZODIAC INTERNATIONAL. UNAUTHORIZED DISCLOSURE, USE OR REPRODUCTION WILL RESULT IN LIABILITY. ZODIAC RESERVES THE RIGHT TO CHANGE THE SPECIFICATIONS OF THIS TECHNICAL DATA SHEET WITHOUT NOTICE.

Dimensions and weight + or - 3 % (5% on prototype)

page 2 / 5



**STANDARD EQUIPMENT**

**BUOYANCY TUBE (GLUED ON)**

BUOYANCY TUBE CONSTRUCTION

- . fabric : military grey, 1670 dtx, polyester, hypalon neoprene in five chambers
- . inflation valves : 5
- . lateral rubbing strake : 3
- . front rubbing strake, bow cross (vertical) : 1
- . exterior lifeline, on D-ring patches : 2
- . interior lifeline, on D-ring patches : 2

**HULL (MILITARY GREY)**

HULL CONSTRUCTION

- . glass reinforced plastic, with grey gel-coat : yes
- . deck with all surface reinforcements : yes
- . hull drain : 1

TRANSOM

- . self-bailers, large flow, w/ scuppers : 2

LIFTING & TOWING

- . bow towing bracket : 2
- . transom towing, stainless steel U-bolt : 2
- . bow lifting stainless steel bracket : 2
- . transom lifting rings, stainless steel U-bolt : 2
- . bow mooring eye, stainless steel U-bolt : 1

**OTHER EQUIPMENT**

- . foot pump : 1
- . repair kit : 1
- . paddles with retaining patches : 2
- . operator's manual : 1

THIS MATERIAL CONTAINS PROPRIETARY DATA BELONGING TO ZODIAC INTERNATIONAL. UNAUTHORIZED DISCLOSURE, USE OR REPRODUCTION WILL RESULT IN LIABILITY. ZODIAC RESERVES THE RIGHT TO CHANGE THE SPECIFICATIONS OF THIS TECHNICAL DATA SHEET WITHOUT NOTICE.

Dimensions and weight + or - 3 % (5% on prototype)

page 3 / 5



# ZODIAC INTERNATIONAL

DIVISION MARINE

## OPTIONS – See Dealer :

- . classic roll-bar with navigation lights
- . self-righting frame with navigation lights
- . consoles and seats configurations
- . DURARIB™ foam collar
- . lifting sling
- . overall cover
- . foot straps
- . console cover
- . additional fuel tank
- . electronics packages

THIS MATERIAL CONTAINS PROPRIETARY DATA BELONGING TO ZODIAC INTERNATIONAL. UNAUTHORIZED DISCLOSURE, USE OR REPRODUCTION WILL RESULT IN LIABILITY. ZODIAC RESERVES THE RIGHT TO CHANGE THE SPECIFICATIONS OF THIS TECHNICAL DATA SHEET WITHOUT NOTICE.

Dimensions and weight + or - 3 % (5% on prototype)

page 4 / 5

**Water Ballast System**

-> Extra Stability when stationary in heavy seas

- When craft loses way : water floods the ballast by the stern, evacuating air at the bow
- When craft increases speed and comes onto the plane : water evacuates by the stern and air entering at the bow

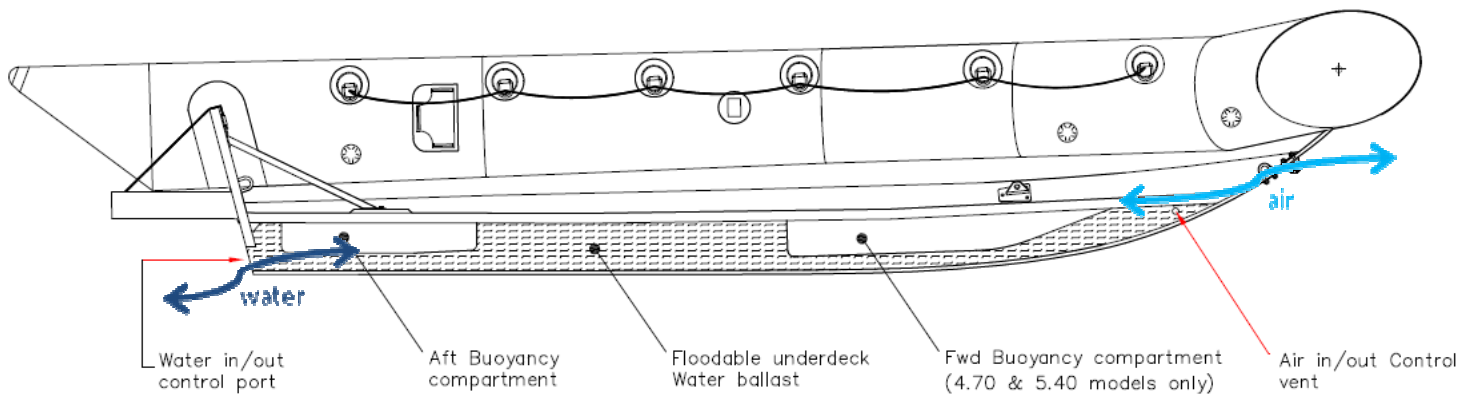

Section along centreline of craft

Section at stern through aft buoyancy compartment

Section on bow

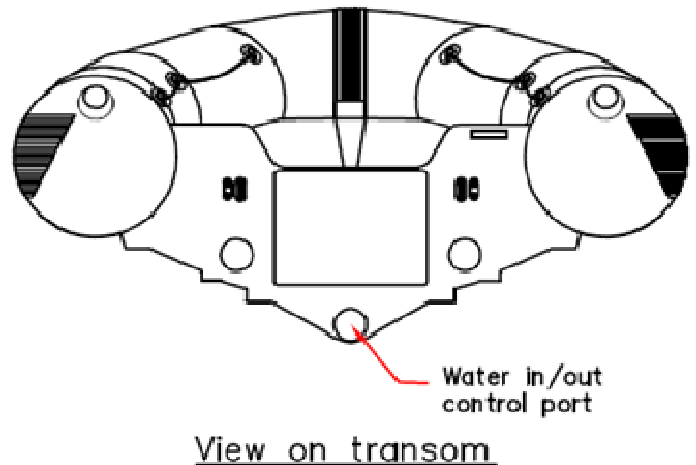
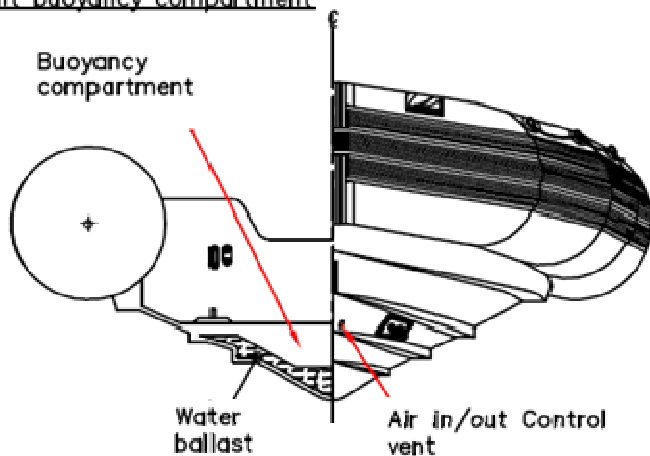

View on transom

THIS MATERIAL CONTAINS PROPRIETARY DATA BELONGING TO ZODIAC INTERNATIONAL. UNAUTHORIZED DISCLOSURE, USE OR REPRODUCTION WILL RESULT IN LIABILITY. ZODIAC RESERVES THE RIGHT TO CHANGE THE SPECIFICATIONS OF THIS TECHNICAL DATA SHEET WITHOUT NOTICE.

Dimensions and weight + or - 3 % (5% on prototype)

page 5 / 5